

- Heavy Industrial
- Self Generating
- Stainless Steel Hermetically Sealed Dual Case
- Frequency Range 4.5Hz to 2kHz
- Sensitivity up to 20mV/mm/sec (500mV/in/sec)
- Choice of cable lengths with or without armouring
- Top or Side exit connector or conduit
- Operating Temperature range -40°C to +100°C
- High Temperature opt. +200°C
- Intrinsically Safe opt. CE Ex II 1G (Ex ia IIC T4)

This self-generating transducer produces a signal proportional to the velocity component of a mechanical vibration by means of relative movement between a coil and a magnet. The rugged construction and fully sealed body enables this transducer to be used in most Industrial environments.

The main body of the transducer is fitted with a polished stainless steel case and contains a moving coil and magnet assembly. The coil is suspended within the field of the magnet by means of diaphragms which permit virtually frictionless movement in one axis only. This measuring axis is coincident with the axis of the cylindrical body.

The devices are simple to interface with monitoring equipment, being passive, and the high sensitivity in conjunction with low noise makes them particularly suitable for power generation applications where the grounding and electrical interference environment is always a challenge. The limited upper frequency response (typically 2kHz) also assists in steam turbine applications where high frequency steam noise can saturate active devices leading to spurious alarms.

Methods of mounting vary from integral, threaded studs of various sizes to integral mounting plates (refer to order codes for details). The transducer is supplied with either an electrical connector fitted to the top or side of the upper body, or an integral top or side exit cable.

Dimensions (shown with primary axis vertical - 0° reference)

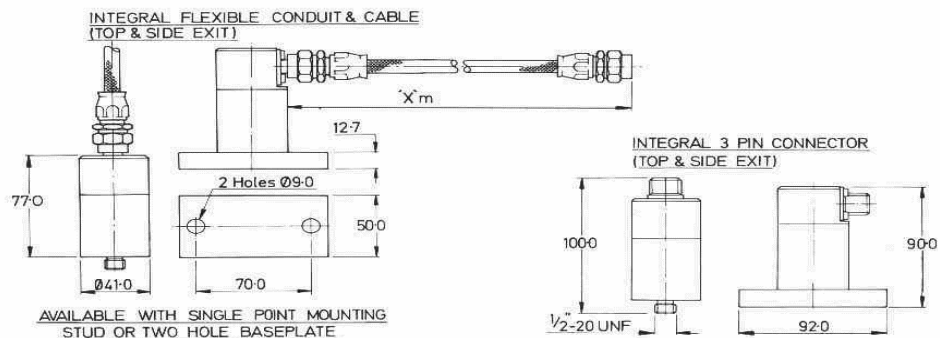

VEL/G SERIES VELOCITY TRANSDUCERS

SPECIFICATION

Output signal	20mV/mm/sec (500mV/in/sec) PK +/- 3%
(10KΩ Load)	or 4mV/mm/sec (100mV/in/sec) PK +/- 3%
	other sensitivities available upon request
Frequency range (3db points)	4.5Hz to 2kHz max.
	Dependent on orientation/sensitivity; see Table 1 below
Linearity	+/- 2% at 100Hz
Max. displacement	2.5mm (100mils) PK to PK
Max acceleration	2000g in sensitive axis
	50g in non-sensitive axis
Output impedance	200Ω nominal
Dimensions	See drawings above
Weight	0.48 kg approx.
Standard Operational temperature range	-40°C to 100°C (high temperature option available upon request)
Connector / Cable orientation	Top or side exit
Certification ATEX.	Ex II 1G (Ex ia IIC T4) Tamb = 100°C

Freq. Range (Hz)	Angle of Calibration	Angular Range of Operation (Degrees) From Angle of Calibration	Max. Sensitivity Deviation	Option (H)
15 - 2000	Vertical 0°	Universal (vertical 0° +/- 180°)	- 10%	1
10 - 2000	Vertical 0°	Universal (vertical 0° +/- 180°)	- 12%	2
10 - 2000	Horizontal 90°	Horizontal (90° +/- 10°)	+/- 2%	3
4.5 - 2000	Horizontal 90°	Horizontal (90° +/- 20°)	- 20%	4
4.5 - 2000	45°	45° +/- 20°	- 10%	5
4.5 - 2000	Vertical 0°	Vertical (0° +/- 20°)	- 6%	6

Table 1. Output sensitivity deviation over frequency range versus mounting angle relative to angle of calibration
 Note:- The primary axis of the sensor is parallel to the cylindrical length of the main body assembly.

ORDERING INFORMATION

VELG -

A Electrical Configuration

- Self Generating, 2 wire

B Connection Method

Integral Economy PVC Cable (80°C) Unarmoured

Integral Cable (140°C) Armoured

Integral Connector, 2 pin, circular, threaded

Integral Connector, 3 pin, circular, threaded

Integral Cable Unarm'd/Braided Flexible Conduit

C Connection / Cable Orientation

Top exit

Side exit

D Mounting Type

¼ in UNF Male

½ in UNF Male

M8

2 Hole Mounting Plate

E Cable / Conduit length

e.g.2m cable, no conduit

e.g.2m conduit, 0.5m excess cable from free end (std)

e.g.2m conduit, 1.0m excess cable from free end

e.g.2m conduit, 1.5m excess cable from free end

e.g.2m conduit, 2.0m excess cable from free end

F Cable/Conduit End Fitting

No cable/conduit end fitting.

¼" BSP female

M16 male

M20 male

G Output Sensitivity

4mV/mm/s (100mV/inch/s) Pk ± 3%

20mV/mm/s (500mV/inch/s) Pk ± 3%

H Frequency band (3dB point) & Mounting

See Table 1 above

I Hazardous Area Approval

Insert '1' for Intrinsically Safe Option, otherwise '0'

L125_3



Sensonics Ltd
 Northbridge Road
 Berkhamsted
 Herts, HP4 1EF
 United Kingdom
 Tel: +44 (0)1442 876833
 Fax: +44 (0)1442 876477
www.sensonics.co.uk