

- **Gas Turbine / Aero Derivative Applications**
- **10mV/g sensitivity**
- **450°C Transducer Operation**
- **Integral Hardline cable with separate charge amplifier**
- **Self Test Facility**

The PZEHT accelerometer is a robust, hermetically sealed instrument suitable for operation in high temperature, heavy industrial environments, such as those found in gas turbine applications. The vibration transducer consists of a piezoelectric sensor, integral hardline cable connected to a charge amplifier unit. This arrangement removes the electronic signal conditioning components from the high temperature environment and provides a 3-wire voltage arrangement at an industry standard sensitivity.

The measuring system incorporates a test and calibration facility that can confirm correct operation of the complete sensing loop. This is an important consideration for high temperature applications, where the sensor is positioned in hard to reach or non-serviceable parts of the turbine. The interface offers a further 2-wire connection for the application of a sinusoidal source to mechanically excite the measuring element for the self test facility. This is only for use with the appropriate Sonsonics signal conditioning equipment.

PZEHT 450°C ACCELEROMETER SPECIFICATION

Electrical

Operating Voltage/Current.....18 to 28 volts dc, 10mA max
 Output signal.....10mV/g \pm 5%
 Bias Voltage..... 12Vdc \pm 1.0V
 Dynamic Range.....Up to \pm 500g peak
 Frequency Range5Hz to 5kHz (better than 3dB)
 Mounted Resonance.....>10kHz
 Calibration Sensitivity at 80Hz.....-60dB (option D2 only)
 Transverse sensitivityLess than 5%
 Amplitude linearity \pm 1% or better
 Residual electrical noise1mg rms typ (5Hz to 5 kHz)

Mechanical

Transducer Material.....Inconel 600, hermetically welded
 Weight.....950 gms (nominal)
 Transducer Mounting.....4-off 7.2mm dia 30.2mm pitch
 Charge Amplifier Mounting3/4BSP
 Connector.....Mil style 6-pin connector (MIL-C-5015)

Environmental

Shock Survival.....<2000g
 Accelerometer Head Temperature Range-55°C to +450°C
 Charge Amplifier Temperature Range.....-30°C to +120°C
 Protection (BS.EN60529)Sealed to IP.67
 Certification ATEX.....CE Ex II 1G (EEx ia IIC T1-T6) contact sales for certification details

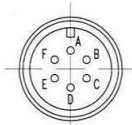

AMPHENOL 6 PIN MIL-C-5015
 CONNECTOR, TYPE 3102F-14S-6P

CONNECTIONS

Pin A — +18 to 28V SUPPLY Pin D — 0V SUPPLY
 Pin B — Sig O/P Lo/CAL I/P Lo Pin E — CAL I/P Hi
 Pin C — Sig O/P Hi Pin F — CASE CONNECTION

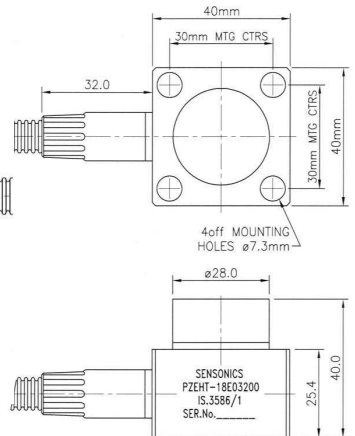
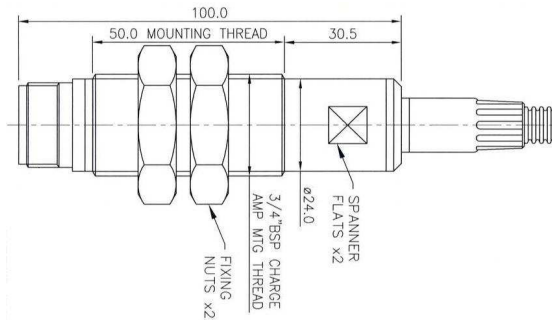

Ordering Information

PZEHT -

A	B	C	D	E	F
1	8 E	0 3	1	0	

A Electrical Configuration

1

 - Integral Charge Amplifier

B Connection Method

8	E
---	---

 3 wire, 6-pin MIL

C Cable length

0	3
---	---

 3 metres. Standard set length

0	6
---	---

 6 metres. Standard set length

D Output & Frequency band (3dB point)

1

 10mV/g \pm 5% (5Hz – 4KHz) 3- wire

2

 10mV/g \pm 5% (5Hz – 4KHz) 4- wire with calibration

E Mounting Thread (Female)

0

 - As above

F Hazardous Area Approval

0

 - Non Intrinsic

1

 - Intrinsic

